

**APPROVED**

COMPANY

TITLE

SIGNATURE

DATE

**Design Details**

Speed (fpm)	60*
Load (lbs.)	481.9
Accumulation	YES
Slider Mat'l	UHMW
Motor V/Ph	575/3
Motor Hp	3/4
Motor Amp Draw	.93
Control V/Ph	N/A

**Belt Details**

Type	32T10
Mat'l	Anti-Static Wrap
Color	Black
Splice	Endless

**SEW EURODRIVE  
GEARMOTOR  
SF37DRN80MK4  
61 RPM, 620 IN-LB**

**\*SPEED 56.0 FPM @ 60Hz  
SPEED 60 FPM @ 64.3Hz**

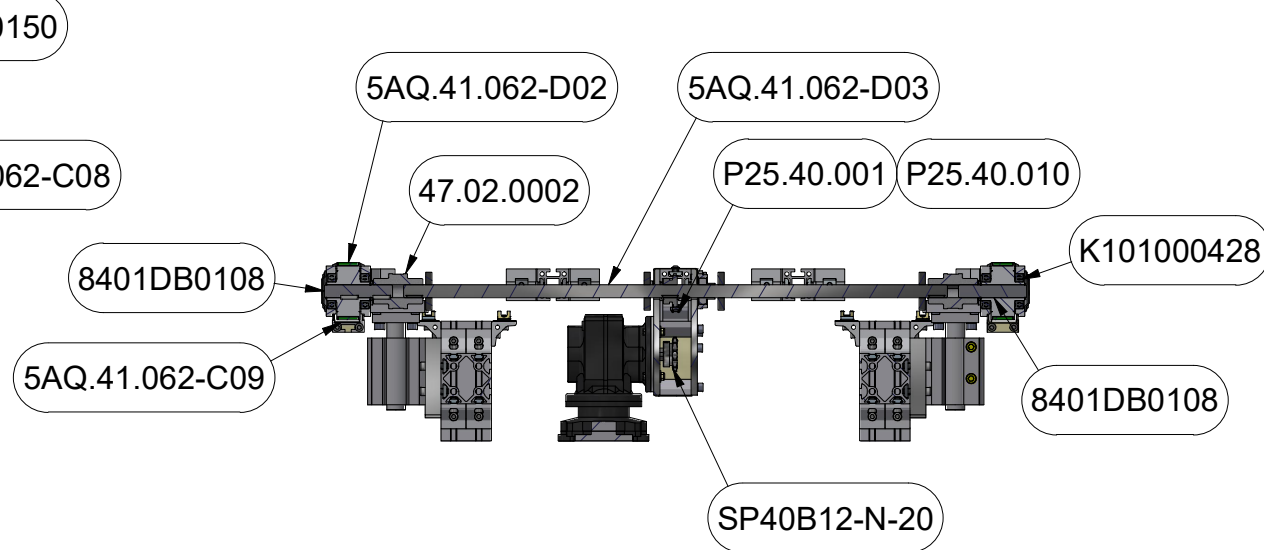
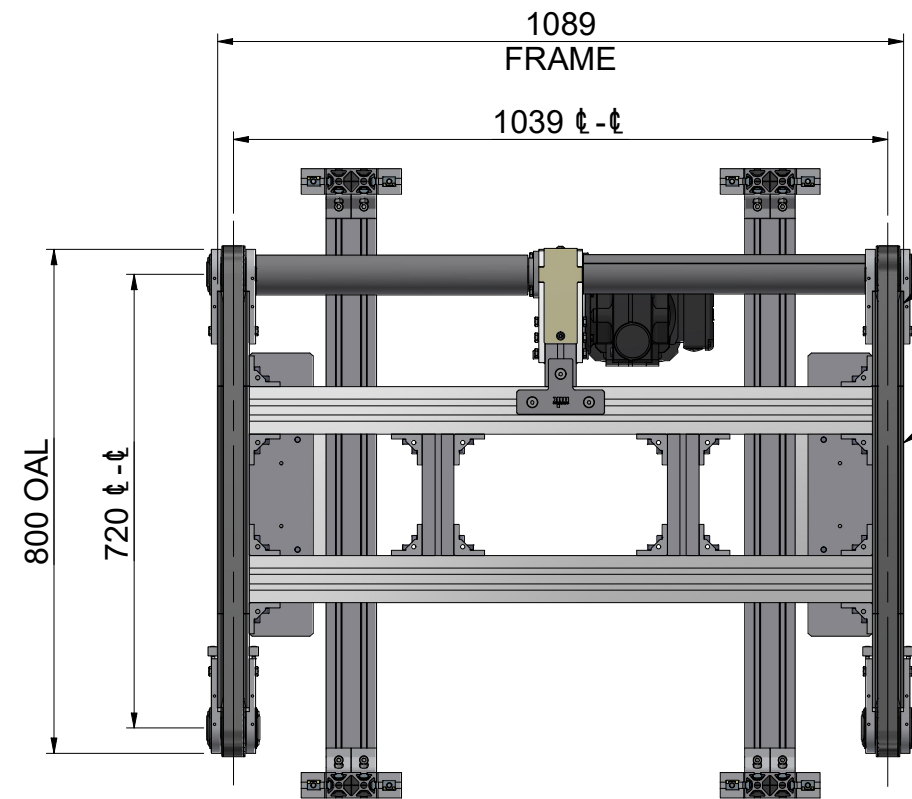

SECTION A-A

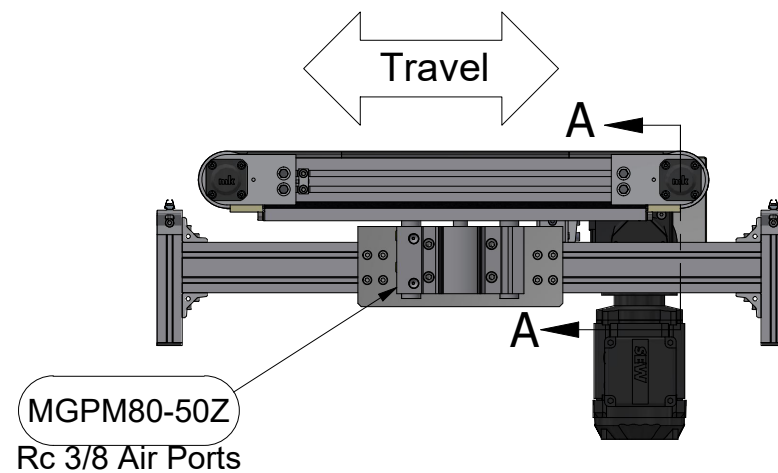
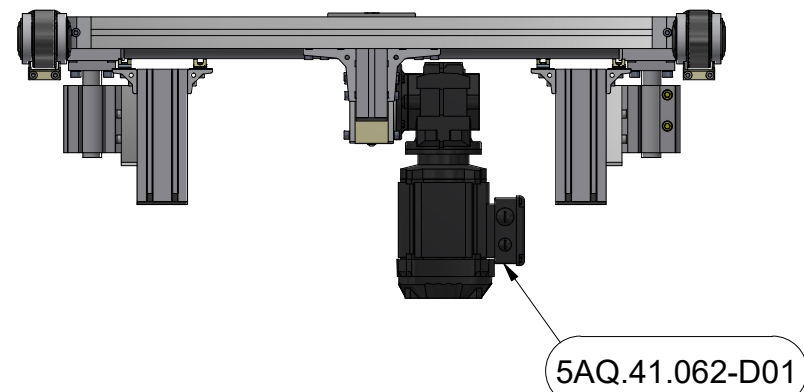

File 5AQ.41.062.iam	MACHINED PARTS TO BE FREE OF SHARP EDGES & BURS REMOVE ALL INK STAMPS, DECALS & BLEMISHES		Sheet size	mk North America, Inc. 105 Highland Park Drive, Bloomfield, CT 06002 Ph: 860.769.5500 www.mknorthamerica.com		
	This document contains proprietary information which shall not be reproduced, transferred to other documents, disclosed to others, used for manufacturing or any other purpose without written permission of mk North America, Inc.		B	NORTH AMERICA, INC. a member of the mk Technology Group		
	-All dimensions in millimeters unless otherwise specified-		Name	Date	Title: HQZ-2010 Timing Belt Lift & Transfer	
	Assembly Tolerances:	Standard Tolerances:	Drawn CC	6/17/2024	Checked	
0 - 1,000 mm: +/- 1 mm	to 3000 ± 1.6	Approved		Approved		
1,001 - 3,000 mm: +/- 2 mm	to 1000 ± 0.8	Matl:		Matl:		
3,001 - 5,000 mm: +/- 5 mm	to 100 ± 0.3	Matl. Qty:		Matl. Qty:		
5,001 - 10,000 mm: +/- 10 mm	to 30 ± 0.2	Revision		Revision		
CTL Tolerance: +/- .5mm	to 6 ± 0.1	Sheet 1 of 1		Sheet 1 of 1		
	1 decimal plcs. ±0.1 2 decimal plcs. ±0.05 Part Tolerances override standard tolerances					