



Aluminum Conveyors & Linear Motion

better products. better solutions.



World

Class

Solutions

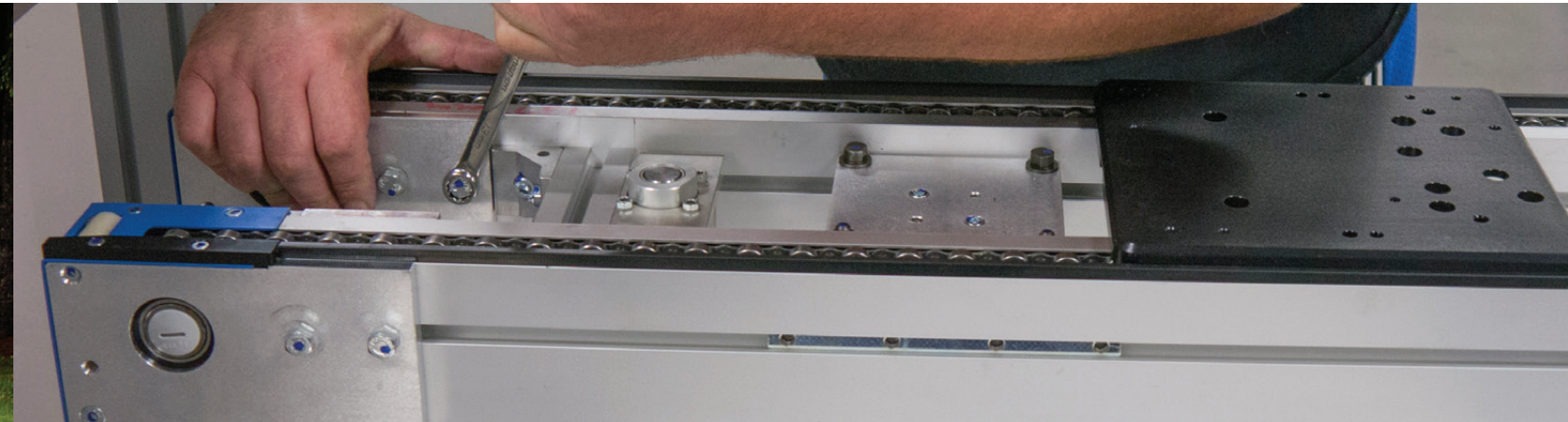

Introduction to mk

mk North America, Inc. is a member of the mk Technology Group and a leading worldwide manufacturer of aluminum conveyors, flat top chain conveyors, pallet-handling systems, and extruded aluminum framing.

Unsurpassed variety, maximum flexibility and easy integration are reasons mk has become the supplier of choice for machine builders, system integrators and manufacturing companies around the globe.

Since 1988 mk North America has been providing diverse industrial know-how, superb quality, constant innovation and application engineering excellence. mk North America offers you the perfect solution for any application.

better products. better solutions.

At mk North America we believe in offering not only better products, but also better solutions. We offer the most extensive product line in the industry; featuring more than 30 different types of conveyors, and 10 different linear motion modules. This allows us to partner with you to provide just the right solution for your needs.

Our broad offering and years of experience in material handling allows us to provide the best equipment for your individual needs. Our innovative conveying and linear motion solutions, both standard and custom, have proven themselves in the automotive, manufacturing, machine builder, metal working, packaging, and printing industries to name a few.

When ordering our conveyors and/or linear motion modules you will experience firsthand the benefits of our innovative designs, competitive pricing and exceptional customer service.

At mk we are dedicated to providing you better products and better solutions.

The mk Commitment

- ✓ Robust construction and high quality components decrease downtime and increase productivity
- ✓ Modular design to reduce engineering costs and lead-times
- ✓ Technical application assistance on every project
- ✓ Competitive pricing
- ✓ Innovative designs
- ✓ Custom solutions

Product Offering

	Page	Belt	Plastic Modular Belt	Timing Belt	Chain	Flat Top Chain	Roller	Cleats	Fixtures	Curves	Inclines	Gliding
CONVEYOR OFFERING												
DGF-P 2001	10	✓									✓	
GUF-P 2000	9	✓						✓				
GUF-P 2041	9	✓						✓			✓	
GUF-P MINI	9	✓										
KFG-P 2000	10	✓						✓			✓	
KGf-P 2000	9	✓								✓		
KFM-P 2040	13		✓							✓		
KMF-P 2040	13		✓									
KTF-P 2010	17				✓							
MBF-P 2040	13		✓					✓			✓	
RBM-P 2255	25						✓					
RBS-P 2065/2066/2255	25						✓			✓		
RBT-P 2255	25						✓			✓		
SBF-P 2000	20					✓				✓		
SPU 2040 Single/Wide/Dual	23					✓						
SRF-P 2010	17				✓							
SRF-P 2012	17				✓							
SRT-P 2005	20					✓				✓		
TKU 2040	17				✓				✓			
VersaFlex A06/A08/A10/A17/A29	19 - 20					✓		✓		✓	✓	
ZRF-P 2010	15			✓								
ZRF-P 2040	15			✓				✓	✓			
ZRF-P 3000	15			✓				✓	✓			
LINEAR MOTION OFFERING												
LZR 2000/2004/2005/2011	39			✓								
VST 2011/2015	39											✓

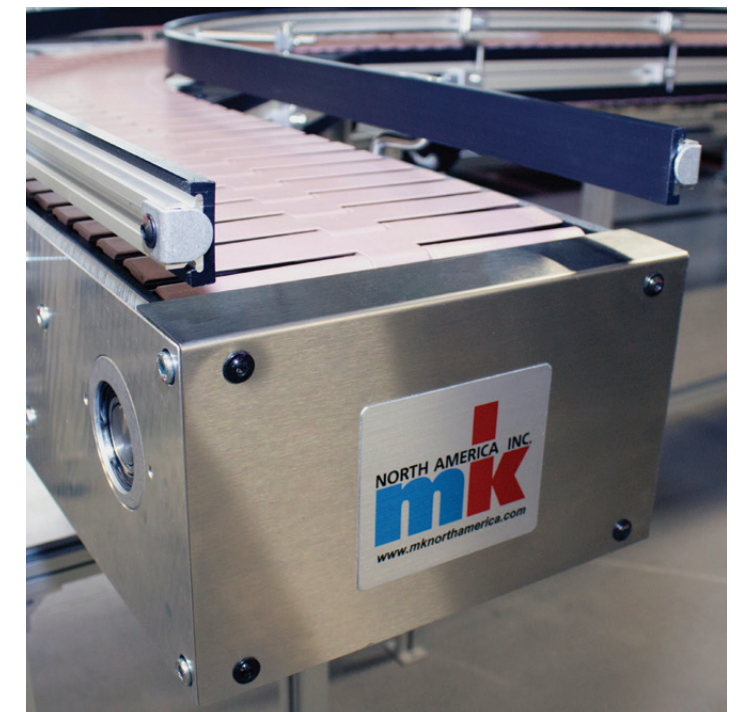
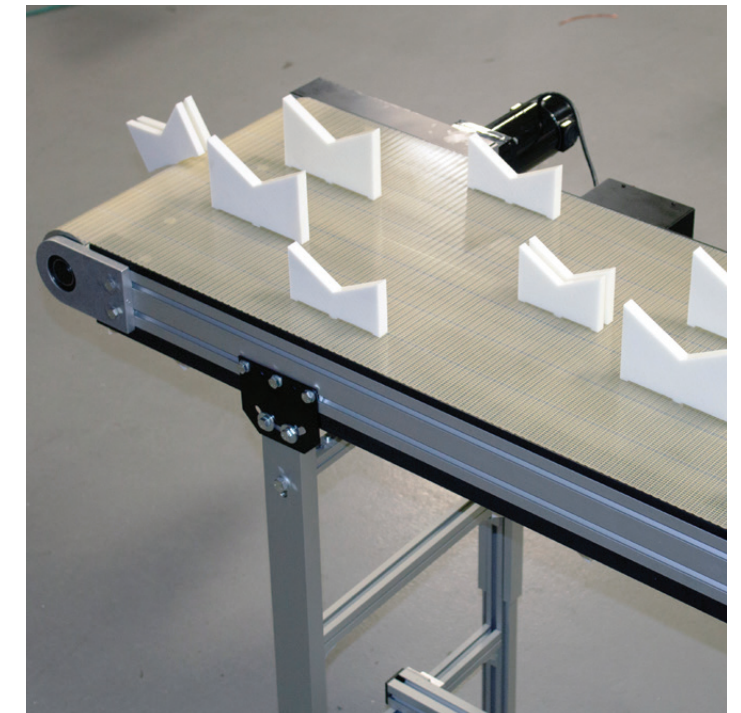

The mk North America Difference



Support

At mk North America we believe in supporting our customers from the initial inquiry through the delivery of their system and beyond. We have a dedicated sales and engineering staff to manage your project. All orders include detailed 3D and 2D models for your review and approval. mk assembles and tests all material handling systems prior to shipping. mk also offers FAT, start up and installation assistance and as well as all replacement and spare parts.

Customizations

mk North America believes in offering not only a better product, but also a better solution. We understand how the performance of your production line affects your business. Regardless of what makes your material handling application unique – temperature, environmental concerns, handling requirements, or space constraints – mk can provide a custom solution that meets your needs and keeps your business moving.

Advantages

- ✓ **Easy installation:** All mk products are assembled and tested prior to shipping
- ✓ **Easy integration:** All mk products work together and are fully compatible
- ✓ **Design without compromise:** mk offers more products and flexibility than anyone else
- ✓ **Cost-effective:** Save time and money by using standard mk products to build custom solutions
- ✓ **High quality components:** Reduce operating expenses and increase productivity
- ✓ **Experience:** Providing customers with functional and cost-effective solutions since 1988
- ✓ **Engineering support:** Full technical and design assistance before, during and after the sale

Online Conveyor Modeling

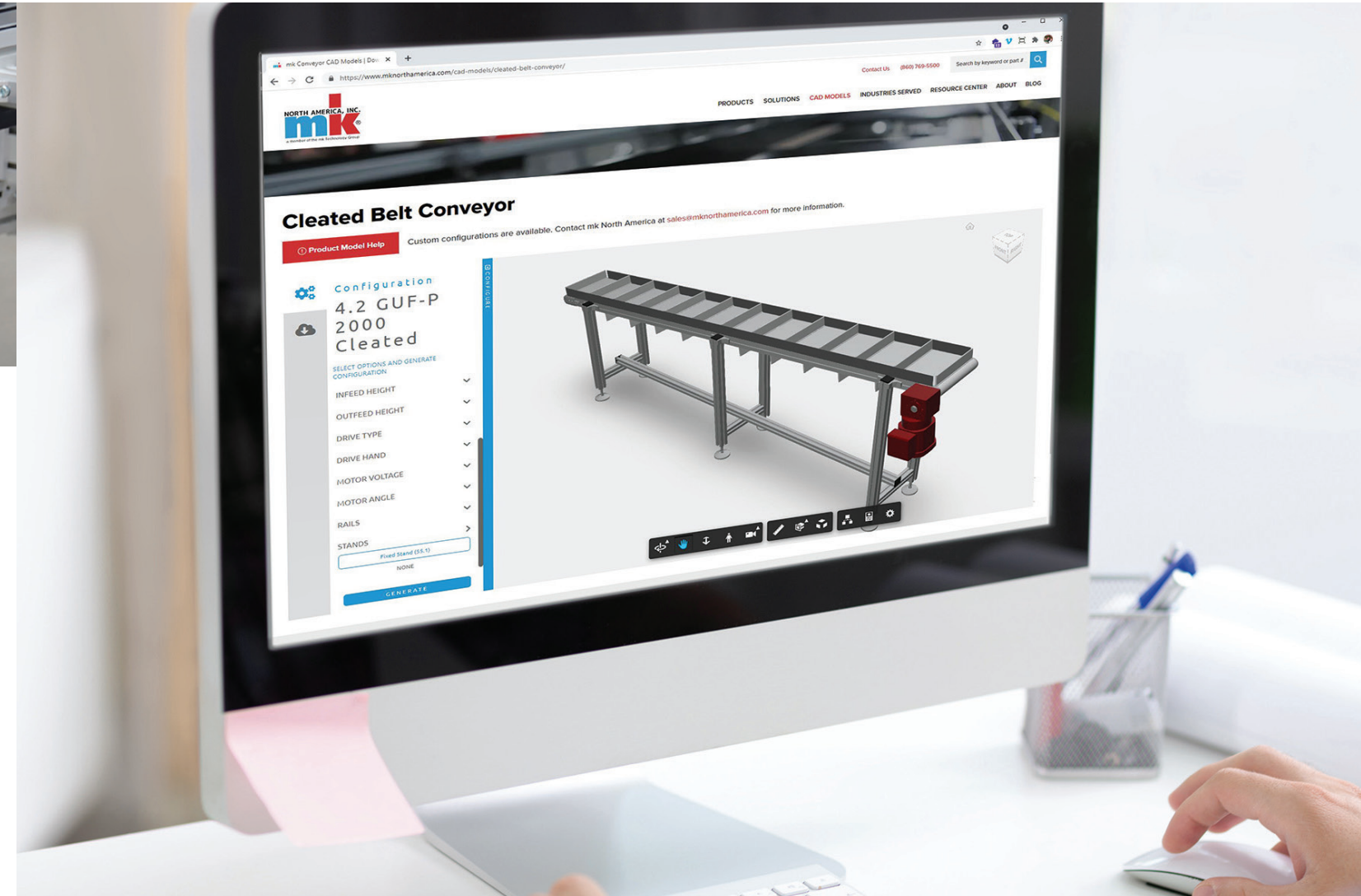

CAD360!

www.mkcad360.com

Quickly and Easily Configure and Download CAD Models

- ✓ A wide range of conveyor platforms are available
- ✓ Customize conveyor lengths and widths, drive locations, stand type and side rails
- ✓ Update the conveyor model instantly
- ✓ A wide variety of download options including: STEP, SAT, 3D and 2D DWG, and PDF files
- ✓ Usable on any device connected to the Internet



Belt conveyors are a versatile staple in nearly every assembly, processing and manufacturing facility. mk North America offers straight-running belt conveyors in three different frame heights; as well as a curve belt conveyor, incline and multi-lane belt conveyors.

Our belt conveyors are constructed out of mk's durable, high-quality, t-slotted aluminum extrusion which allows for easy mounting of accessories. All mk belt conveyors feature a wide selection of drives, idlers, stands, and side rails.

Applications and Industries

- Assembly
- Packaging
- Injection molding
- System integration
- Part accumulation
- Small part handling
- Metal stamping industries
- Testing and inspection lines
- Elevation change applications
- Printing, labeling, scanning and marking
- Original Equipment Manufacturers (OEM)

Features and Benefits

- Quick belt change
- Fast delivery available
- Cleats and sidewalls available
- Strong, ladder frame construction
- End and mid-drive models available
- Maintenance free, sealed, high quality bearings
- Nose bar transfers as small as 10 mm diameter
- Cleats and flights possible on many models
- Crowned pulleys for:
 - Optimal belt tracking
 - and Long belt life

GUF-P MINI



The GUF-P MINI conveyor features a low 35 mm frame height, ideal for small parts handling or slug removal. It is available in three standard widths with a variety of drive and tail options.

Frame: 35 mm deep structural aluminum profile
Width: 75, 100, and 150 mm
Lengths: Up to 5,000 mm
Loads: Up to 100 lbs.
Speeds: Up to 200 fpm

GUF-P 2000



The GUF-P 2000 is our most popular and most versatile conveyor; and it features more drive, idler and belt options than any of our other conveyor models.

Frame: 50 mm deep structural aluminum profile
Width: 50 to 300 mm (in 50 mm increments), 400 to 800 mm (in 100 mm increments)
Lengths: Up to 10,000 mm
Loads: Up to 300 lbs.
Speeds: Up to 500 fpm

GUF-P 2041



The GUF-P 2041 series conveyors are manufactured using our structural 40 x 80 mm profile. The result is a modular, heavy-duty frame with dual t-slots, ideal for wide product applications and heavy loads.

Frame: 80 mm deep structural aluminum profile
Width: 200 to 1,200 mm (in 100 mm increments)
Lengths: Up to 10,000 mm
Loads: Up to 500 lbs.
Speeds: Up to 500 fpm

KGF-P 2040



Belt curve conveyor system KGF-P 2040 comes in a variety of angles and widths. The system features a 20 mm rolling nose bar, on each end, which allows for the transfer of small parts.

Frame: Constructed out of multiple 40 mm deep profiles
Width: 300, 400, 500 and 600 mm
Radii Angle: 45°, 60°, 90° and 180°
Loads: Up to 75 lbs.
Speeds: Up to 75 fpm

KFG-P 2000



The KFG-P 2000 is designed to move products between various elevations. This conveyor can be configured with horizontals at the infeed, discharge or both ends and can feature an incline or decline section.

Frame: 50 mm deep structural aluminum profile
 Width: 300 to 700 mm (in 100 mm increments)
 Lengths: Up to 4,000 mm
 Loads: Up to 150 lbs.
 Speeds: Up to 75 fpm

DGF-P 2001

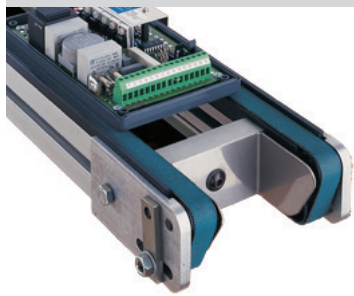

The DGF-P 2001 is a dual belt conveyor designed specifically for edge handling small pallets. This conveyor is ideal for compact spaces and applications.

Frame: 50 mm deep structural aluminum profile
 Width: Pallet size plus 11mm
 Lengths: Up to 2,000 mm
 Loads: Up to 50 lbs.
 Speeds: Up to 75 fpm



KFG-P 2000 Incline to Horizontal Conveyor feeds product over and onto the conveyor below, which then carries the product downstream.



Conveyors from mk North America, like these GUF-P 2000 Belt Conveyors, can easily be modified to include a variety of accessories, such as safety guards.



GUF-P 2000 Belt Conveyors have many idler options including a 19 mm rolling nose bar, as shown above.



Here a GUF-P MINI Belt Conveyor with a center drive is customized with side rails unique for the application.

Modular Plastic Belt Conveyors

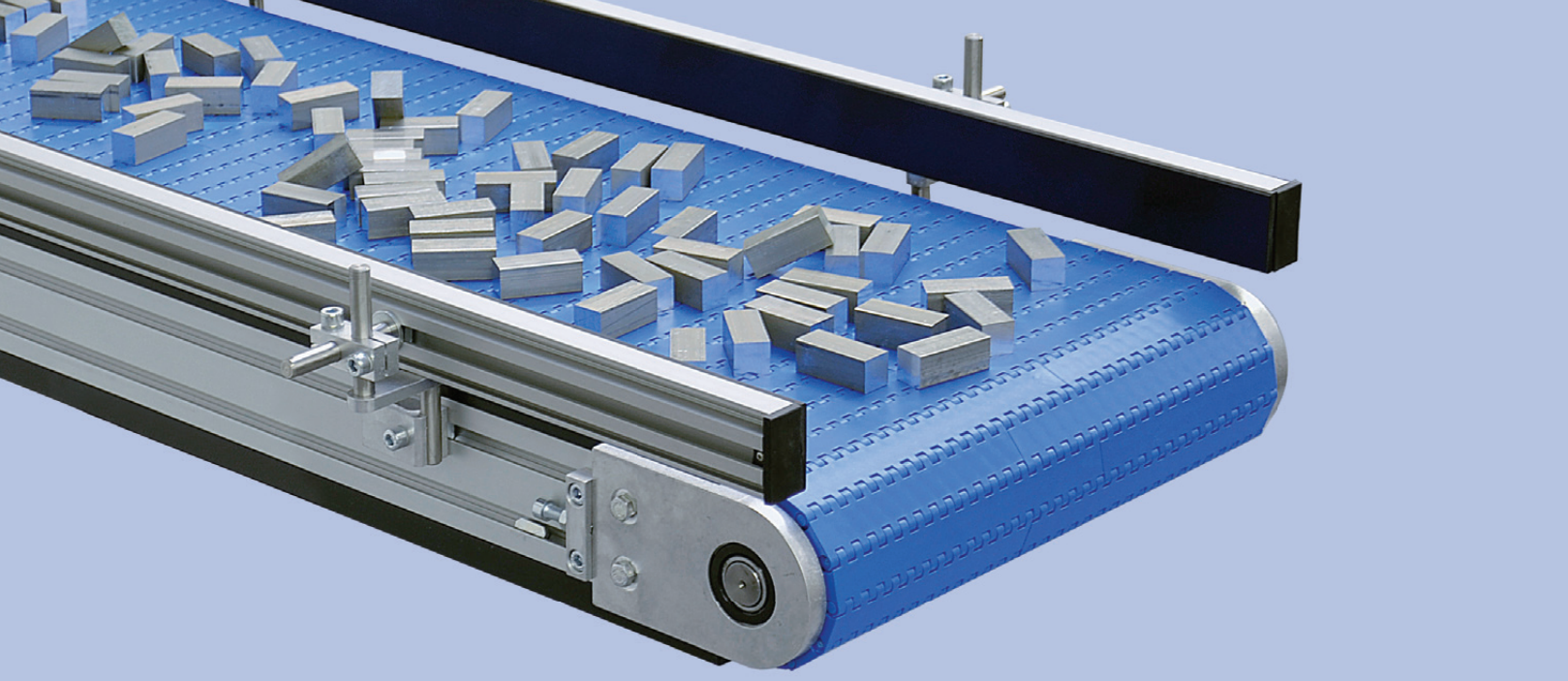

mk North America's modular plastic belt conveyors come in a variety of platforms and configurations. What distinguishes these from traditional belt conveyors is their high load capacities, even at narrow belt widths. The modular plastic belt is positively driven, which reduces belt tracking difficulties.

Because the plastic belt is built in interlocking segments, it is possible to replace a damaged portion of belting, without replacing the entire conveyor belt, thus resulting in cost savings. The modular plastic belt is also resistant to wear and is low-friction, making it ideal for those applications involving high temperatures or caustic chemicals. This conveyor's high load capacity also makes it useful for heavy material handling, as in automotive or general manufacturing applications.

Applications and Industries

- Assembly
- Sorting lines
- Automotive industry
- Part accumulation
- System integration
- Cooling and curing lines
- Metal stamping industries
- Testing and inspection lines
- Original Equipment Manufacturers (OEM)

Features and Benefits

- Positively driven
- Cleats and flights available
- Nose bar transfers possible
- Strong, ladder frame construction
- Maintenance free, sealed, high quality bearings
- Rapid belt change and the flexibility to replace only portions of the belt
- A wide variety of belting choices offered in various plastics and styles

MBF-P 2040

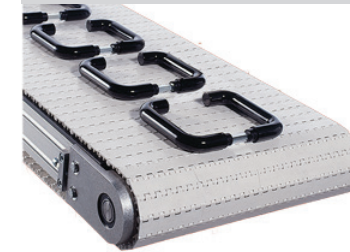

The MBF-P 2040 conveyor is a rugged and durable modular plastic belt conveyor. This conveyor is ideal for high loads and wide widths.

Frame: 80 mm deep structural aluminum profile
 Width: Up to 3,000 mm
 Lengths: Up to 10,000 mm
 Loads: Up to 1,000 lbs.
 Speeds: Up to 200 fpm

KMF-P 2040

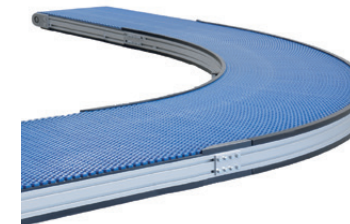

The KMF-P 2040 comes in a variety of different widths and can handle multiple curves with a single drive. The frame is only 30 mm wider than the belt, making this conveyor highly compact.

Frame: 80 mm deep structural aluminum profile
 Width: 164 mm to 1,005 mm
 Loads: Up to 330 lbs.
 Speeds: Up to 100 fpm

KFM-P 2040



The KFM-P 2040 conveyor system, with its compact conveyor frame structure, is well suited for integration into existing machines and moving product between elevations.

Frame: 80 mm deep structural aluminum profile
 Width: 200 to 1,000 mm
 Lengths: Up to 4,000 mm
 Loads: Up to 300 lbs.
 Speeds: Up to 100 fpm

Timing Belt Conveyors

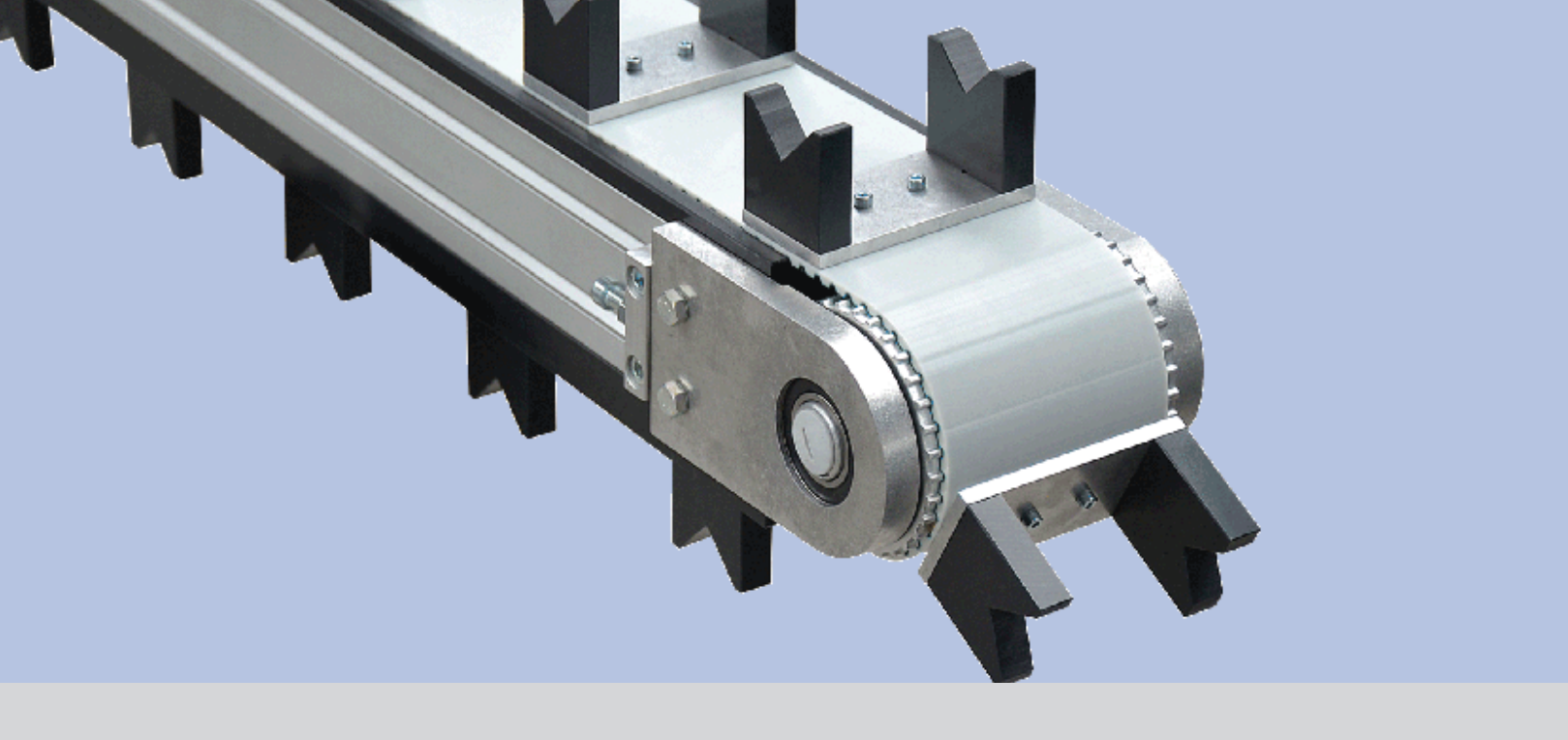

Timing belt conveyors are the ideal choice in indexing applications and those requiring precise product location. The modular frame construction of mk North America's timing belt conveyors allow for easy additions and expansions to the conveyor line, plus the limitless ability to mount accessories to the frame.

mk North America offers three different timing belt conveyors, each uniquely positioned to provide the right conveyor solution for the application. The ZRF-P 2010 is ideal for handling pallets or wide parts that can be supported over several belts. The ZRF-P 2040 is a very robust conveyor and has the highest weight capacity of mk's timing belt conveyors. The ZRF-P 3000 is a wide timing belt conveyor that offers a variety of belting options, along with a high precision indexing package.

Applications and Industries

- Testing
- Assembly
- Cycled, indexing or continuous movement
- System integration
- Automotive industry
- Precision movement
- General manufacturing
- Workpiece holding and positioning
- Original Equipment Manufacturers (OEM)

Features and Benefits

- Positively driven
- Wide variety of options
- Precise positioning and locating
- Single and multi-strand configurations
- Cleats, fixtures and attachments possible
- Maintenance free, sealed, high quality bearings

ZRF-P 2010

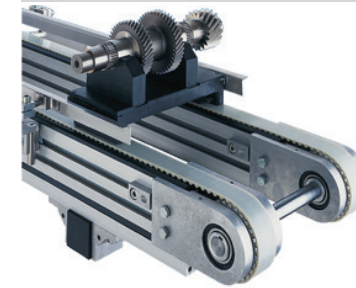

Timing belt conveyor ZRF-P 2010 is ideal for indexing applications and for the design of pallet handling systems. The belt returns within the conveyor frame.

Frame: 100 mm deep structural aluminum profile
Width: A single lane 50 mm wide, or set up as multiple lanes
Lengths: Up to 10,000 mm
Loads: Up to 800 lbs.
Speeds: Up to 200 fpm

ZRF-P 2040

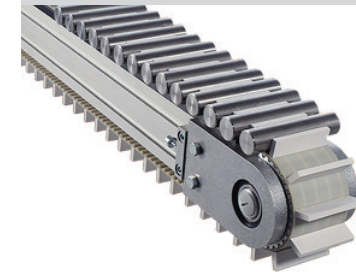

The ZRF-P 2040 timing belt conveyor is unique in its design as it allows for timing belts with either welded or bolted attachments. Available in single or multi-belt configurations.

Frame: 80 mm deep structural aluminum profile
Width: 40, 80 and 120 mm
Lengths: Up to 10,000 mm
Loads: Up to 1,500 lbs.
Speeds: Up to 200 fpm

ZRF-P 3000



ZRF-P 3000 is a wide timing belt, featuring a low-profile frame, and a unique motor package that allows for precise indexing and highly repeatable operation. This conveyor can be supplied with a smooth belt, cleated belt or with inserts for mounting fixtures to.

Frame: 40 mm deep structural aluminum profile
Width: 120 to 620 mm
Lengths: Up to 10,000 mm
Loads: Up to 300 lbs.
Speeds: Up to 500 fpm

Chain Conveyors



mk North America's chain conveyors are the go-to conveyors for all of your pallet-handling needs. mk offers the most extensive line of chain conveyors in the industry; with various types of accumulating roller chain to standard roller chain in single or duplex strands, as well as attachment chain conveyors.

For over-under applications the TKU 2040 is the perfect fit. This attachment chain conveyor is designed to have pallets or fixtures mounted directly to the chain. Additionally, the TKU has the option to have an adjustable width (with the driven lane fixed in position).

Applications and Industries

- Testing
- Assembly
- Sharp parts
- Pallet handling
- Machine builders
- Automotive industry
- Fixtured applications
- Workpiece positioning
- Indexing and positioning
- Accumulation and storage
- Original Equipment Manufacturers (OEM)

Features and Benefits

- Positively driven
- Optional integrated side rails
- Wide variety of chain options
- High quality chains for long life
- Maintenance free, sealed, high quality bearings

KTF-P 2010



The KTF-P 2010 chain conveyor serves as the basic system component for the manufacture of single, dual, or triple-strand material handling systems.

Frame: 100 mm deep structural aluminum profile
Width: A multi-lane system, with each lane 50 mm wide
Lengths: Up to 15,000 mm
Loads: Up to 2,200 lbs.
Speeds: Up to 200 fpm

SRF-P 2010

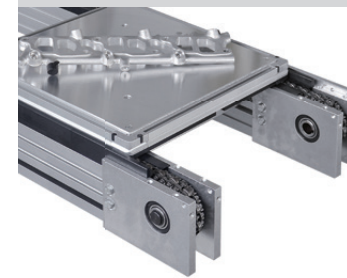

mk's low back pressure accumulating roller chain conveyor, SRF-P 2010, is designed for medium-duty pallet-handling systems.

Frame: 100 mm deep structural aluminum profile
Width: A multi-lane system, with each lane 50 mm wide
Lengths: Up to 20,000 mm
Loads: Up to 2,000 lbs.
Speeds: Up to 200 fpm

SRF-P 2012

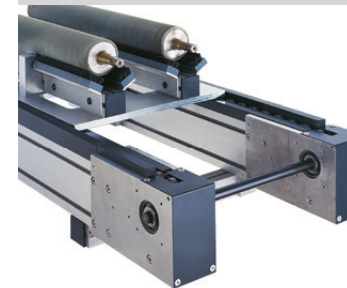

The SRF-P 2012 is a low back pressure accumulating roller chain conveyor designed for heavy-duty pallet-handling systems.

Frame: 120 mm deep structural aluminum profile
Width: A multi-lane system, with each lane 60 mm wide
Lengths: Up to 20,000 mm
Loads: Up to 3,500 lbs.
Speeds: Up to 200 fpm

TKU 2040

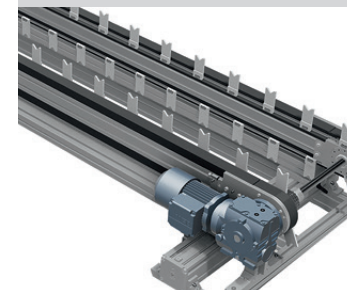

The TKU 2040 is an (optional) adjustable width, indexing chain, conveyor. It can be designed to accommodate pallets or v-blocks.

Frame: 80 mm deep structural aluminum profile
Width: A multi-lane system, with each lane 40 mm wide
Lengths: Up to 8,000 mm
Loads: Up to 1,000 lbs.
Speeds: Up to 60 fpm

Table Top Chain Conveyors



Table top chain conveyors, also called flat top chain conveyors, are used in a wide variety of applications and across many industries. VersaFlex from mk North America is a flexible flat top chain that effortlessly conveys product in three-dimensions – vertically, horizontally, and around corners.

Aside from VersaFlex, mk offers other table top chain conveyors. The SBF-P 2000 is a heavy duty conveyor, that allows for the use of steel chain, and the SRT-P 2005 is for carrying parts in a continuous loop.

mk North America offers a wide variety of modules from curves to incline units, end transfers, and as well as an assortment of chain materials and types. Whatever your needs, our table top chain conveyors are second to none.

Applications and Industries

- Bottling
- Printing
- Packaging
- Sorting lines
- Pallet handling
- System integration
- Automotive industry
- General manufacturing
- Metal stamping industries
- Part accumulation and storage
- Original Equipment Manufacturer (OEM)

Features and Benefits

- Easily configure complex layouts
- Steel and plastic chains available
- Sort, merge and divert all on one conveyor
- Suitable for product or small pallet handling
- Modular design allows for future line changes
- Maintenance free, sealed, high quality bearings
- Designed around industry standard flat top chain widths

VersaFlex A06



The A06 is the narrowest width table-top chain conveyor that mk offers. Part of the VersaFlex lineup it is capable to conveying horizontally, vertically, and around corners.

Frame: 72 mm high
 Width: 45 mm, chain width is 64 mm
 Lengths: Up to 40,000 mm
 Speeds: Up to 165 fpm
 Curves: 90°, 180° and others with a minimum radius of 150 mm

VersaFlex A08



VersaFlex A08 is our most popular table-top chain conveyor. The VersaFlex A08 features a myriad of chain types and styles and is capable to conveying product in the most complex of layouts and designs.

Frame: 85 mm high
 Width: 85 mm, chain width is 83 mm
 Lengths: Up to 30,000 mm
 Speeds: Up to 165 fpm
 Curves: 90°, 180° and others with a minimum radius of 160 mm

VersaFlex A10



The VersaFlex A10 is capable of incline and vertical conveying, alpine configurations, and side gripping applications. VersaFlex A10 is truly a versatile flexible chain conveyor designed to handle almost any industrial conveying application.

Frame: 86 mm high
 Width: 105 mm, chain width is 103 mm
 Lengths: Up to 30,000 mm
 Speeds: Up to 165 fpm
 Curves: 90°, 180° and others with a minimum radius of 170 mm

VersaFlex A17



The VersaFlex A17 is flexible table top chain conveyor for products 70 to 400 mm wide and can be used across a variety of industries including packaging, automotive and consumer goods.

Frame: 95 mm high
 Width: 195 mm, chain width is 175 mm
 Lengths: Up to 30,000 mm
 Speeds: Up to 165 fpm
 Curves: 90°, 180° and others with a minimum radius of 500 mm

VersaFlex A29



The VersaFlex A29 is similar to the A17 model in that it can be used to transport goods from 70 to 400 mm, however this model offers more stability to wider products than the A17 conveyor line.

Frame: 95 mm high
 Width: 300 mm, chain width is 295 mm
 Lengths: Up to 30,000 mm
 Speeds: Up to 165 fpm
 Curves: 90°, 180° and others with a minimum radius of 500 mm

SBF-P 2000



The SBF-P 2000 is designed to operate in the most taxing of environments while carrying a wide variety of products. It can be configured as a single straight run or with a variety of curves.

Frame: 50 mm deep, heavy duty structural profile
 Width: For chain widths: 6", 7.5", 10" and 12"
 Lengths: Up to 10,000 mm
 Speeds: Up to 200 fpm
 Curves: 90° and 180°, radii from 200 mm to 600 mm

SRT-P 2005

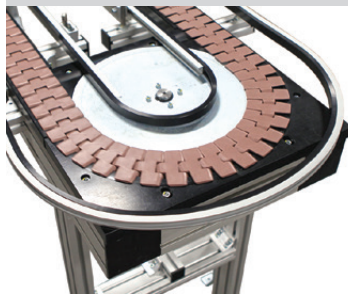

The SRT-P 2005 recirculating flat top chain conveyor is designed to act in a "carousel" fashion – the chain completely circulates along the top surface of the conveyor.

Frame: 100 mm deep, heavy duty structural profile
 Width: For chain width: 3.25"; however larger pallets can be accommodated
 Speeds: Up to 30 fpm
 Configurations: Continuous loop and L-shape



VersaFlex conveyors are ideal for conveying product in multiple directions and to multiple destination locations.



VersaFlex conveyors can be used to convey product, pallets or pucks – depending on the application.

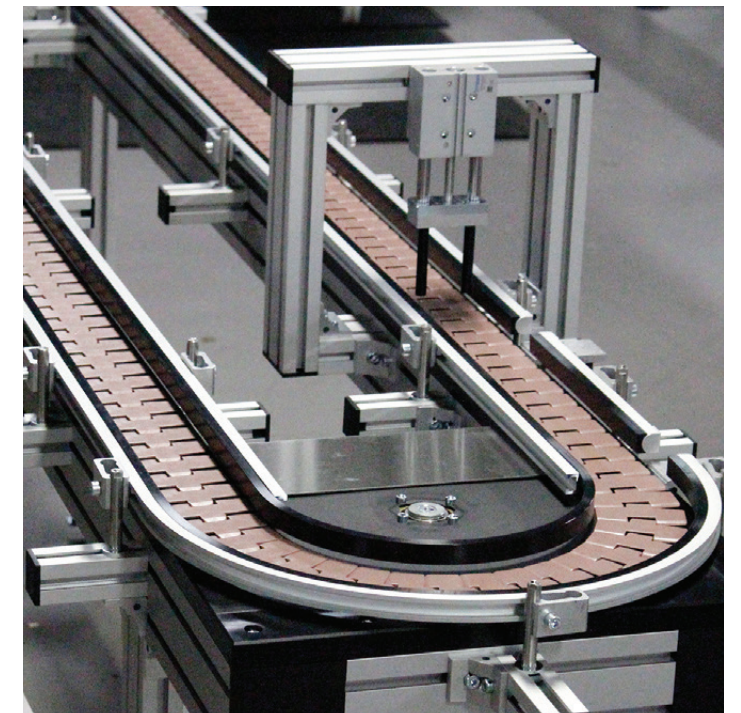

The SRT-P 2005 conveyor, as well as all other Flat Top Chain Conveyors, can be equipped with pneumatic stop and locating devices.

Recirculating Chain Conveyors

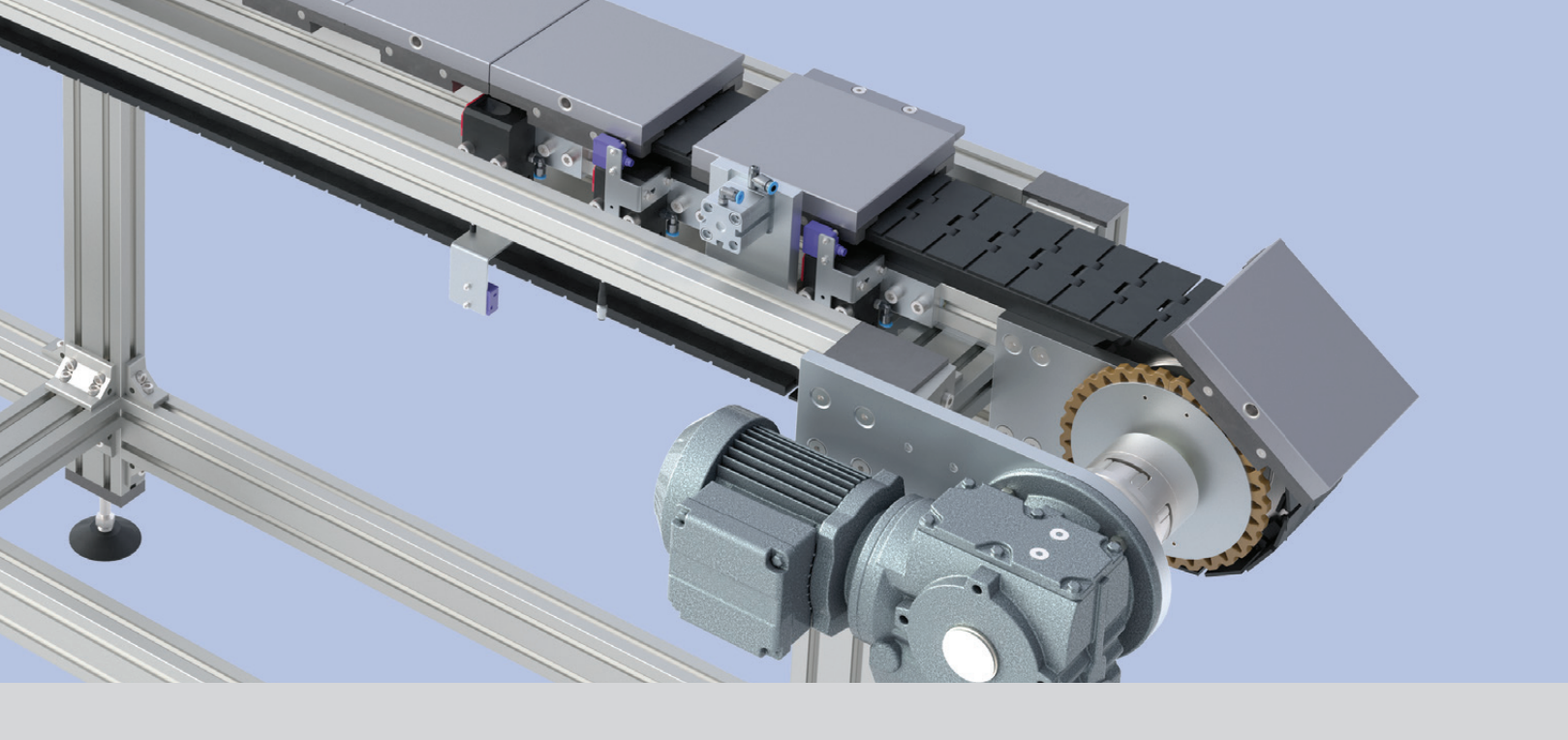

The SPU-2040 is an accumulating, pallet-recirculating, conveyor system which offers: feeding, buffering, positioning and separating of workpieces in the smallest possible space. The robustness and the variety of the various models allows it to be used in practically all areas of automation and material flow.

Workpieces and parts are loaded on the conveyor pallet at the infeed. At the discharge end of the conveyor the parts are removed from the pallets; and the pallets then travel, with the chain; under the conveyor and back to the infeed of the conveyor. This conveyor system eliminates the need for vertical transfer units on either end of the conveyor for pallet recirculation.

The SPU 2040 features a steel flat top chain, installed on a rugged t-slot aluminum extrusion conveyor frame.

Applications and Industries

- Pallet handling
- System integration
- Automotive industry
- General manufacturing
- Machined parts industries
- Over under conveyor systems
- Original Equipment Manufacturer (OEM)

Features and Benefits

- Steel table top chain
- Reliable and dynamic feeding, buffering, positioning and separating of pallets and product
- Compact design with space saving recirculation of pallets on the conveyor chain return
- Allows for buffering and accumulation of product between machines with differing cycle times

SPU 2040 Single

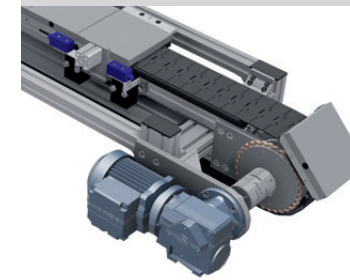

The SPU 2040 is designed to recirculate pallets ranging from 160 mm to 500 mm wide. Pallets are made from aluminum plate material or mk 40 series aluminum extrusion.

Chain Width: 114 or 190 mm
 Lengths: Up to 10,000 mm
 Speeds: 15 to 50 fpm
 Loads: Up to 660 lbs.

SPU 2040 Wide

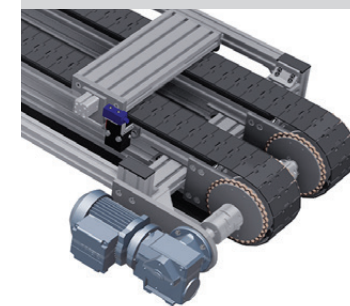

The SPU 2040 Wide conveyor is designed to recirculate pallets starting at 410 mm wide, which are supported over two stands of table top chain.

Chain Width: 114 mm
 Lengths: Up to 10,000 mm
 Speeds: 15 to 50 fpm
 Loads: Up to 990 lbs.

SPU 2040 Dual

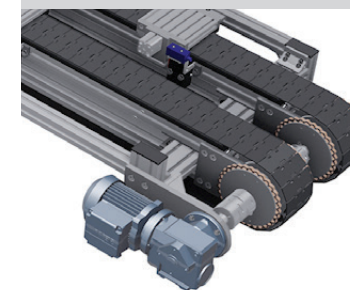

The SPU 2040 Dual conveyor is designed to recirculate two independent rows of pallets on two different strands of table top chain. The pallets are 160 mm wide in this configuration.

Chain Width: 114 mm
 Lengths: Up to 10,000 mm
 Speeds: 15 to 50 fpm
 Loads: Up to 1,330 lbs.

Roller Conveyors



mk North America offers a vast variety of roller conveyors including gravity and driven system options. Featuring various frame and drive designs; including powered rollers and driven rollers, mk roller conveyors can be modified and used as pallet-handling lines as well.

Roller conveyors from mk can be supplied in straight running and curved configurations.

Applications and Industries

- Sorting
- Transfers
- Assembly
- Packaging
- Parts queuing
- General manufacturing

Features and Benefits

- Flexible roller placement
- Steel and plastic roller options
- Efficient transfer system for high loads
- Customizable length and width options
- Wide variety of roller sizes and materials
- Gravity, driven and powered roller options

RBS-P 2065/2066/2255

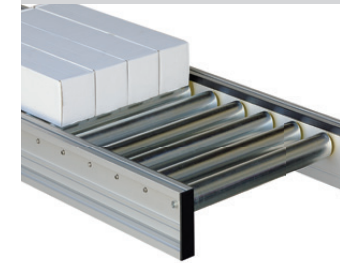

mk's RBS series conveyors are gravity roller units. They are available in three different frame depths and feature customizable roller types, sizes and spacing.

Frame: RBS-P 2065: 75 mm deep, single t-slot, per frame side
 RBS-P 2066: 100 mm deep, dual t-slot, per frame side
 RBS-P 2255: 120 mm deep, dual t-slot, per frame side
 Lengths: Up to 10,000 mm

RBT-P 2255



Chain driven roller conveyors, such as the RBT-P 2255, allow application possibilities such as separation of products, product accumulation, stopping and storage. This unit is powered using an external motor.

Frame: 120 mm deep, t-slots top and bottom
 Width: Starting at 420 mm and up
 Lengths: Up to 10,000 mm
 Speeds: Up to 100 fpm

RBM-P 2255



The RBM-P 2255 is a zero pressure, v-belt driven live-roller conveyor for zoned applications. These powered roller conveyors are also excellent for small tight spaces and short lengths.

Frame: 120 mm deep, t-slots top and bottom
 Width: Starting at 420 mm and up
 Lengths: Up to 10,000 mm
 Speeds: Dependent on load

Aluminum Conveyor Examples



Side rails on all mk conveyors can be customized, and are designed to work within each application's unique nature.



Many Plastic Modular Belt and traditional Belt Conveyors can be outfitted with belting that includes sidewalls and cleats, as shown here.



TKU 2040 conveyors are designed to carry a wide variety of products, and with an adjustable width feature their versatility is unlimited.



Roller Conveyors are ideal for transporting oversized parts. Timing Belt Conveyors are used to transfer parts between perpendicular Roller Conveyors.



SPU 2040 Recirculating Pallet-Handling Conveyors can be designed to carry one or two rows of pallets.



Inserts are placed into Timing Belts, this allows fixtures to be bolted to the belt, as seen in this example.



Accumulating Roller Chain Conveyors, like this SRF-P 2010, are ideal for accumulating workpiece pallets.

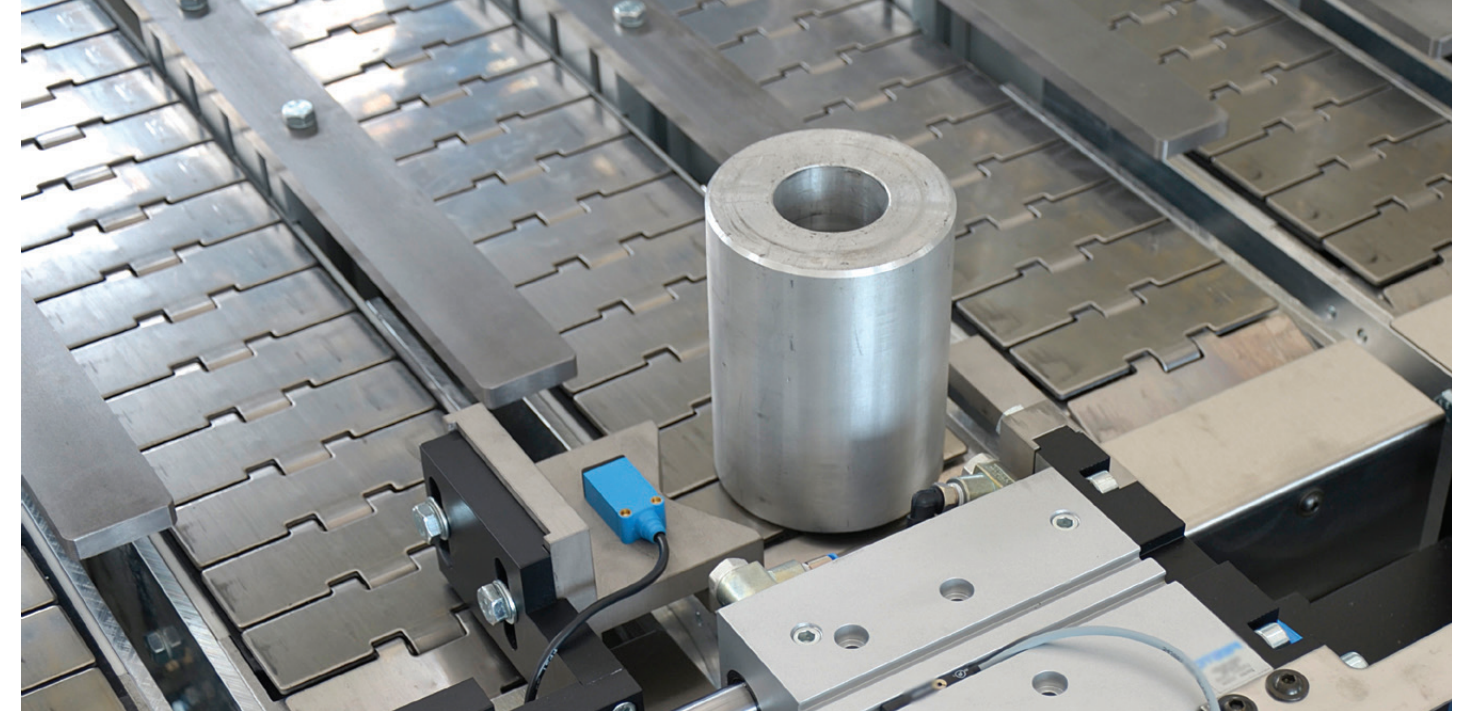

Many conveyors can be arranged to carry multiple rows of parts at a time, such as these SBF-P 2000 Table Top Chain Conveyors.

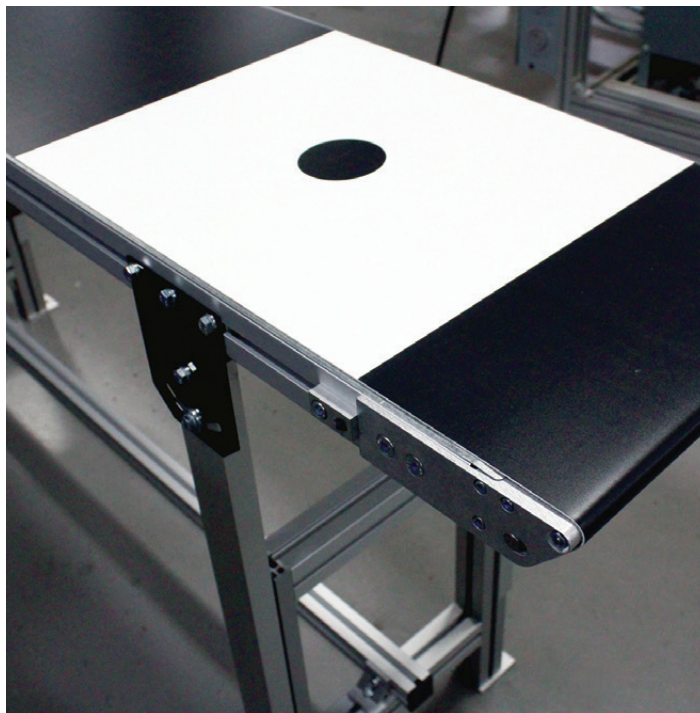

There are nearly limitless belting options available for mk's Belt Conveyors, including belts with custom printed surfaces – such as the one shown above.

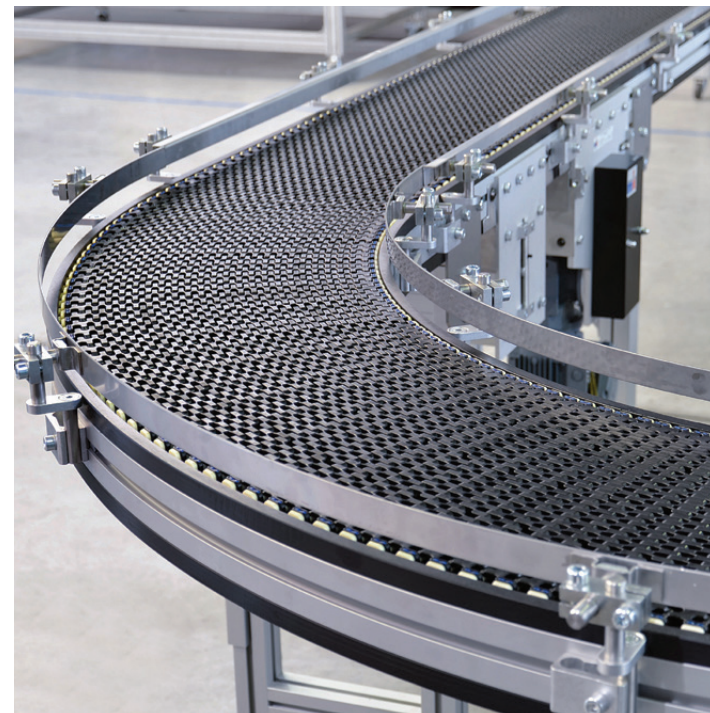

KMF-P 2040 Plastic Modular Belt Conveyors can be configured in a variety of ways and can include single or multiple curves.



KFM-P 2040 Plastic Modular Belt Conveyors are ideal for incline conveying. These conveyors can be configured with horizontals on either or both ends of the conveyor.

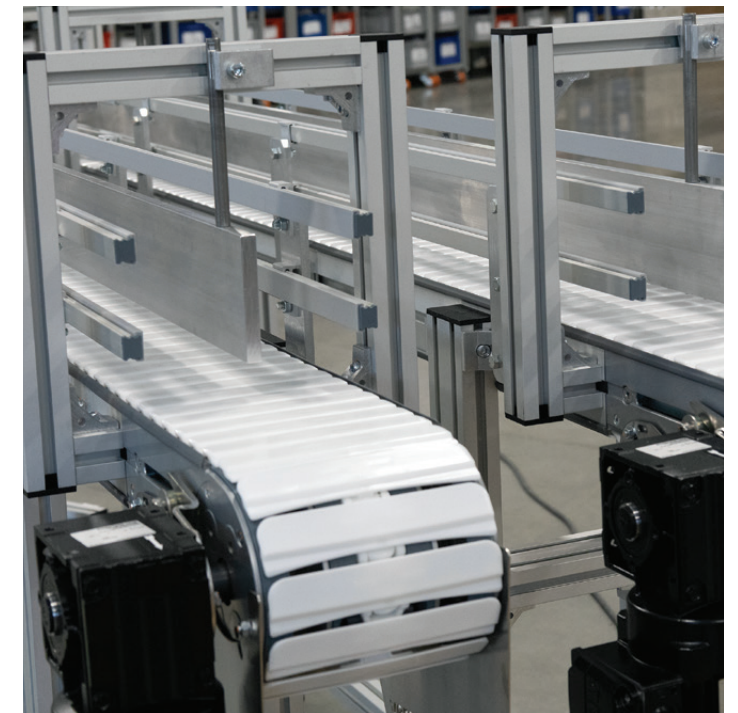

VersaFlex, Flat Top Chain Conveyors, come in a variety of conveyor widths and can carry products up to 400 mm wide.

Engineered Conveyor Solutions



mk has the largest offering of standard conveyors on the market, allowing us to provide the most comprehensive selection of custom engineered conveying solutions. From modified standard designs to truly one-of-a-kind custom conveyors, mk has the solution for you.

Applications

- Indexing
- Specialty Belting
- Vision & Inspection
- Special Environment
- Accumulation & Storage
- Part Orientation & Positioning

Features and Benefits

- Highly customizable
- Fully built and tested prior to shipping
- Specifically designed to meet unique demands
- Engineering support before, during and after the sale
- Designed using standard mk conveyors for cost effective solutions

Accumulation & Storage

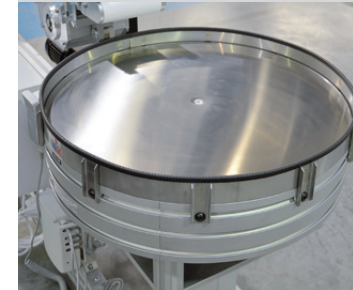

Accumulation and storage conveyors allow you to better manage your production.

- Turntables
- Low pressure accumulation
- Recirculating conveyors
- Vertical storage units
- Zone driven accumulation
- Bi-flow tables

Indexing



Indexing solutions allow for accurate, precise and measured movements of the product.

- Attachment chain conveyors
- Attachment timing belt conveyors
- Indexing motor and controls including servo and steppers
- A variety of accessories including sensors and encoders

Parts Orientation & Positioning

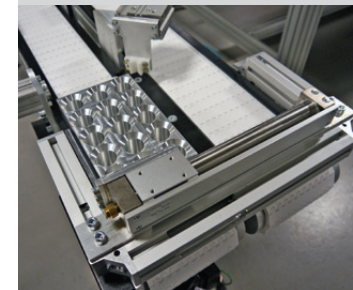

mk offers a wide variety of parts orienting accessories such as end stops, nests and product fixtures in addition to conveyors specifically designed for positioning and orientating purposes.

- Adjustable width conveyors
- Magnetic conveyors
- Rotating conveyors
- Side gripper conveyors
- Vacuum conveyors

Special Environment



Looking to install a conveyor in a particular environment? Then look no further than mk.

- Abrasive applications
- Caustic cleaning or environments
- Cleanroom
- Explosion proof
- Temperature extremes (hot or cold)
- Washdown

Specialty Belting

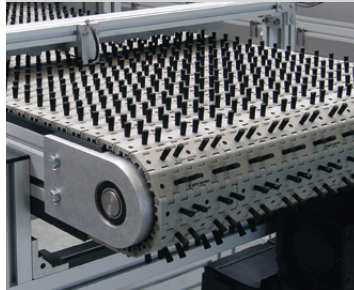

Specialty belting can make an ordinary conveyor extraordinary and capable of meeting demanding requirements.

- Anti-static and highly conductive belting
- Extreme temperature belting
- Narrow width belts
- Stainless steel belts
- Roller top belting
- Woven wire belting

Vision & Inspection

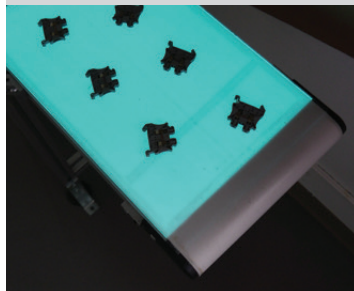

mk offers a wide variety of conveyors to aid in the vision and inspection of various products.

- Back-lit conveyors
- Metal detector conveyors
- Hugger style conveyors

Customs

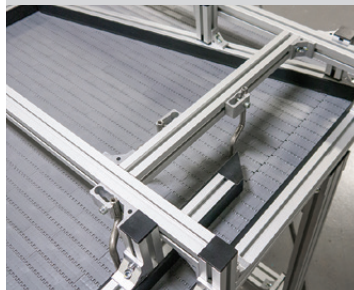

mk North America provides the broadest offering of conveyor types in the industry; but we recognize that unique and specialized solutions are often required. mk will work with you to develop a solution to meet your specific needs.

- Back-lit conveyors
- Metal detector conveyors
- Hugger style conveyors

Engineered Conveyor Solutions Examples

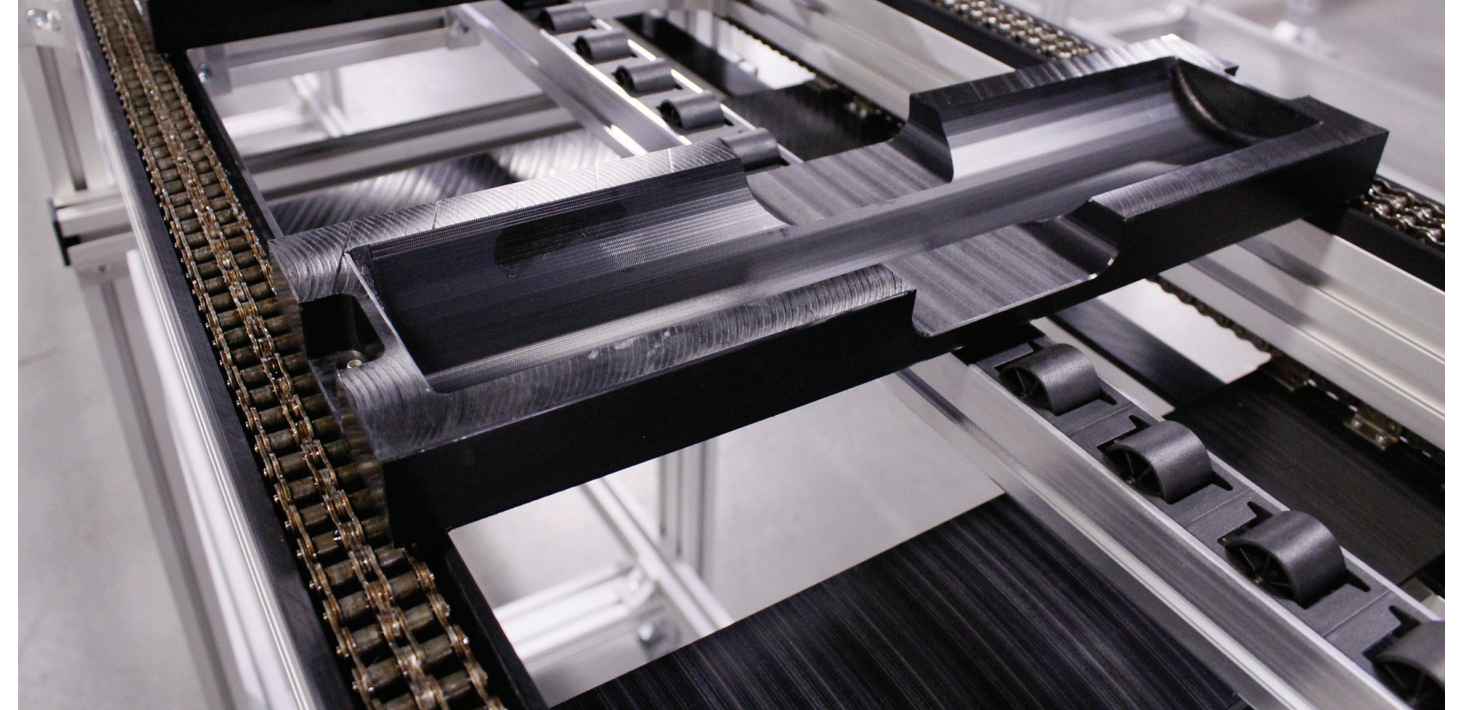

In this Custom Conveyor example, a plastic pallet is affixed to the roller chain, additionally gravity wheels support the center of the pallet.

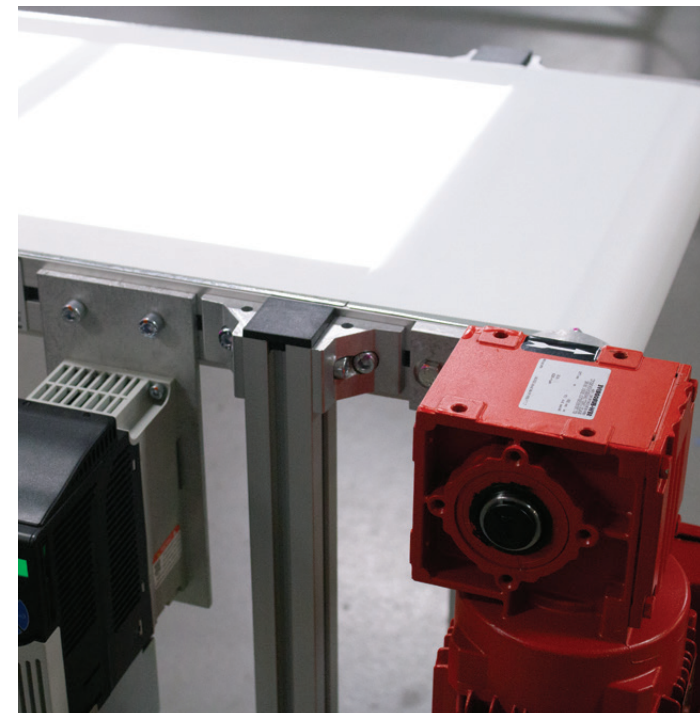

Back-lit Conveyors bring light into areas where it is needed most. These conveyors can feature a single or multiple light panels.



Conveyors can be designed so that they run on their edges. This can be extremely useful when it is necessary to grip products by their sides.



Parts can be metered off of a conveyor line using a pneumatic escapement.



Modul-con conveyors are ideal for moving product around corners in a fixed position from each other.

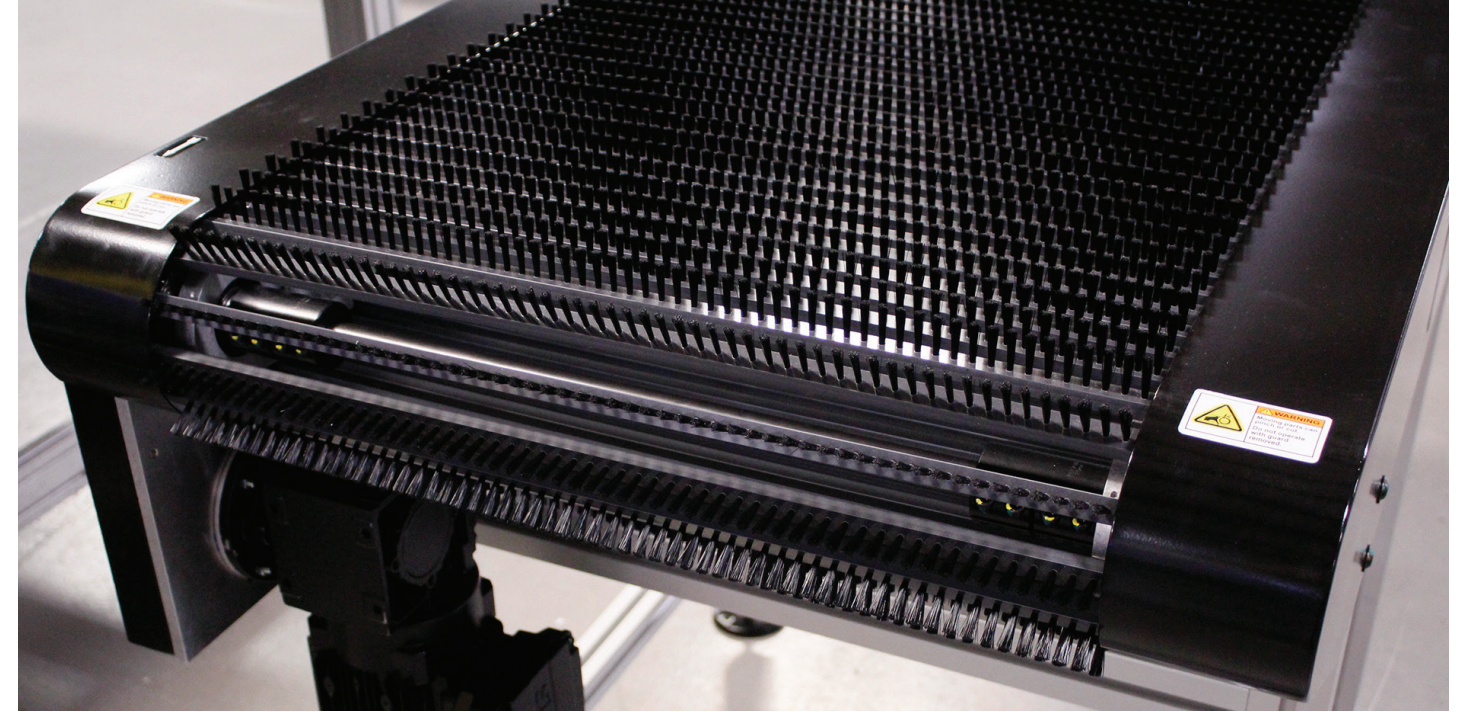

In this Engineered Conveyor Solution, brushes are used to carry sheets of glass between stations.

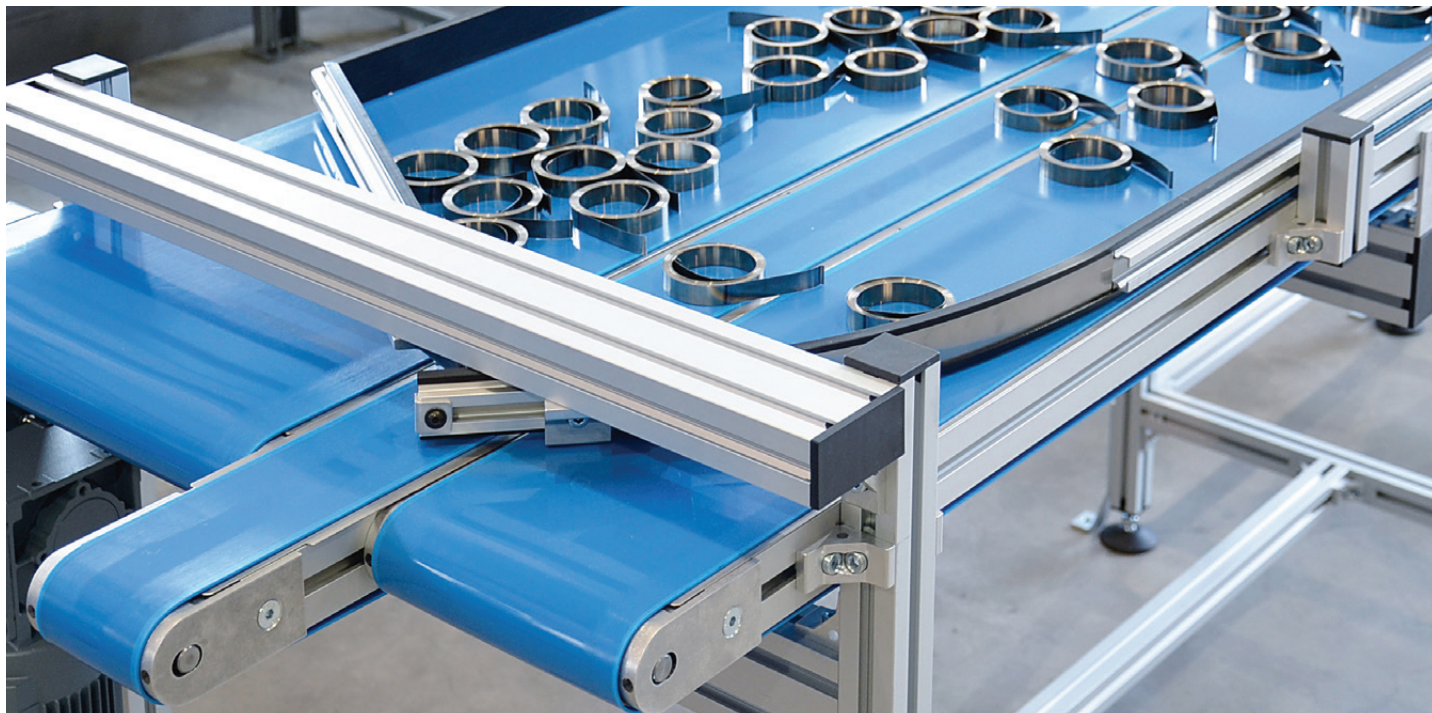

A wide variety of conveyors can be used to accumulate and store parts, including belt conveyors as shown here.



The DTZ-P 2040 Turntable is excellent for accumulating product between workstations, or for product overflow.



The KFS-P 2040.86 is a Heavy-duty Hinged-steel Belted Conveyor. This conveyor is ideal for carrying hot or sharp products.

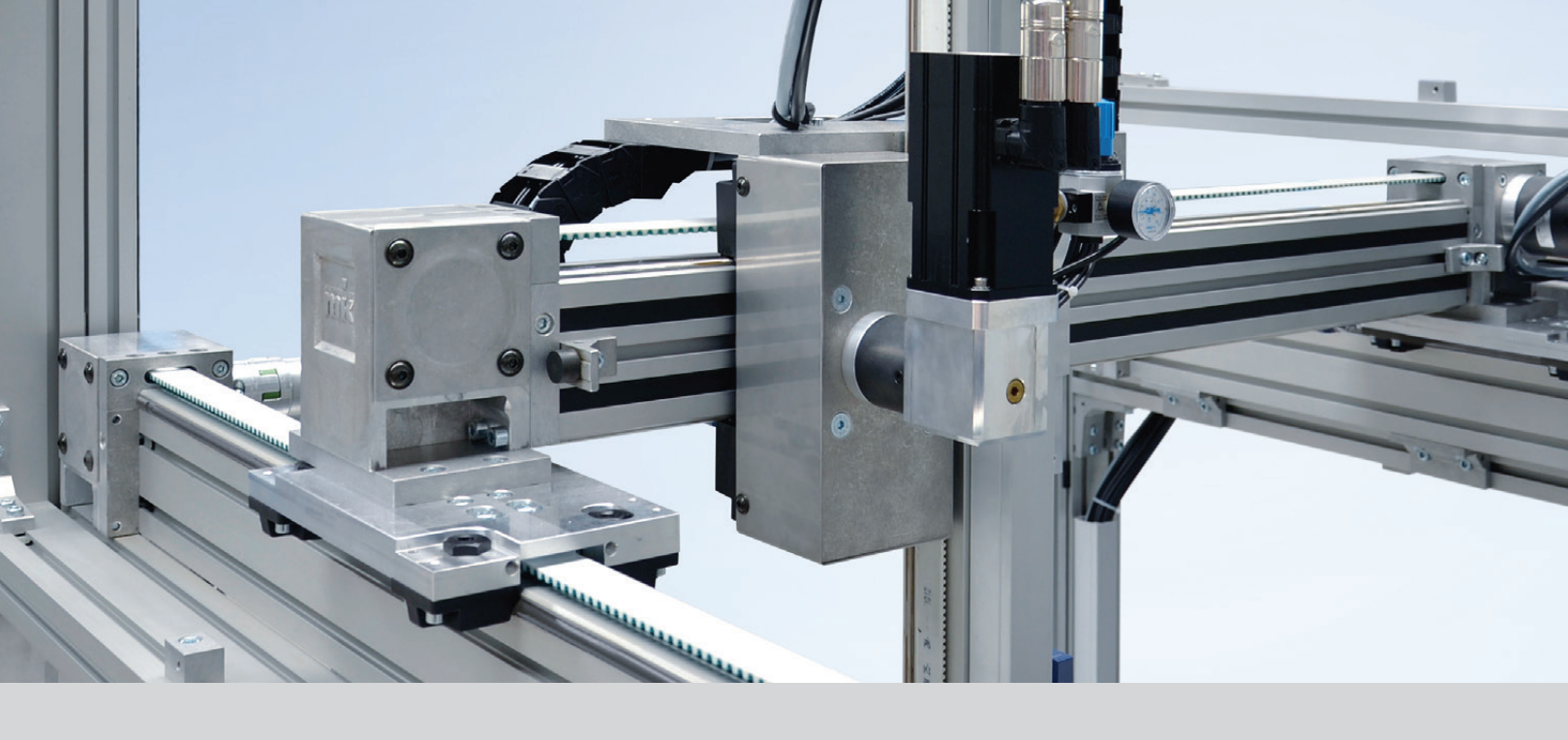

mk offers a comprehensive line of precision linear motion products for demanding manufacturing applications. All mk linear motion products are available in standard or custom configurations, ranging from simple manual positioning units to complex multi-axis gantries used in high-speed automation.

All mk linear motion products are modular and fully compatible with mk's aluminum framing system and conveyors. The "add-on" principle allows for easy integration of our linear modules into existing framework, resulting in significant savings in materials and labor.

Applications and Industries

- Indexing
- Positioning
- Rapid rail adjustment
- Adjustable width conveyors
- Printer head and dispensing
- Pharmaceuticals and biomedicine
- Side-gripping conveyor supports and adjustment

Features and Benefits

- Compatible with mk aluminum extrusions, which saves on materials, costs and space
- The wide range of guides are designed to meet the customer's requirements
- Simple and rapid setup of linear positioning modules based on the "add-on" principle
- Highly reliable operation; modules are built with the highest quality materials
- mk engineers provide expert advice and assistance in designing your system

LZR

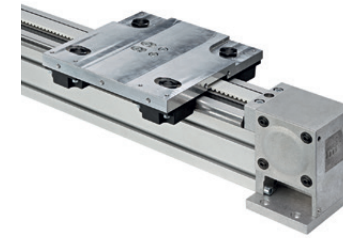

The mk LZR, timing belt driven linear module, offers high speed, high acceleration, and a long travel distance, in addition to a rigid construction. They are ideally suited to operate as a single-axis product or as a component in multi-axis gantries.

Sizes: 50x50 mm, 50x100 mm and 100x100 mm profile cross sections
Carriages: 150 mm, 250 mm and 450 mm long
Carriage Mounting: Top or Side Mounted
F_{Allowable}: Up to 4,000 N

VST



mk linear positioning module, VST, is designed for adjustment and positioning tasks. Typical applications include measuring, labeling, scanning, printing and marking. The structural profile features a high-quality surface coating that provides a low-friction travel surface for the carriage. A stainless steel cover strip protects the trapezoidal spindle from contaminants, making the VST virtually maintenance-free.

Sizes: 50x50 mm and 100x100 mm profile cross sections
Designs: Single carriage, Dual carriages – Opposing-directions or Same-direction
Display Options: No display, With Scale, With Digital Display

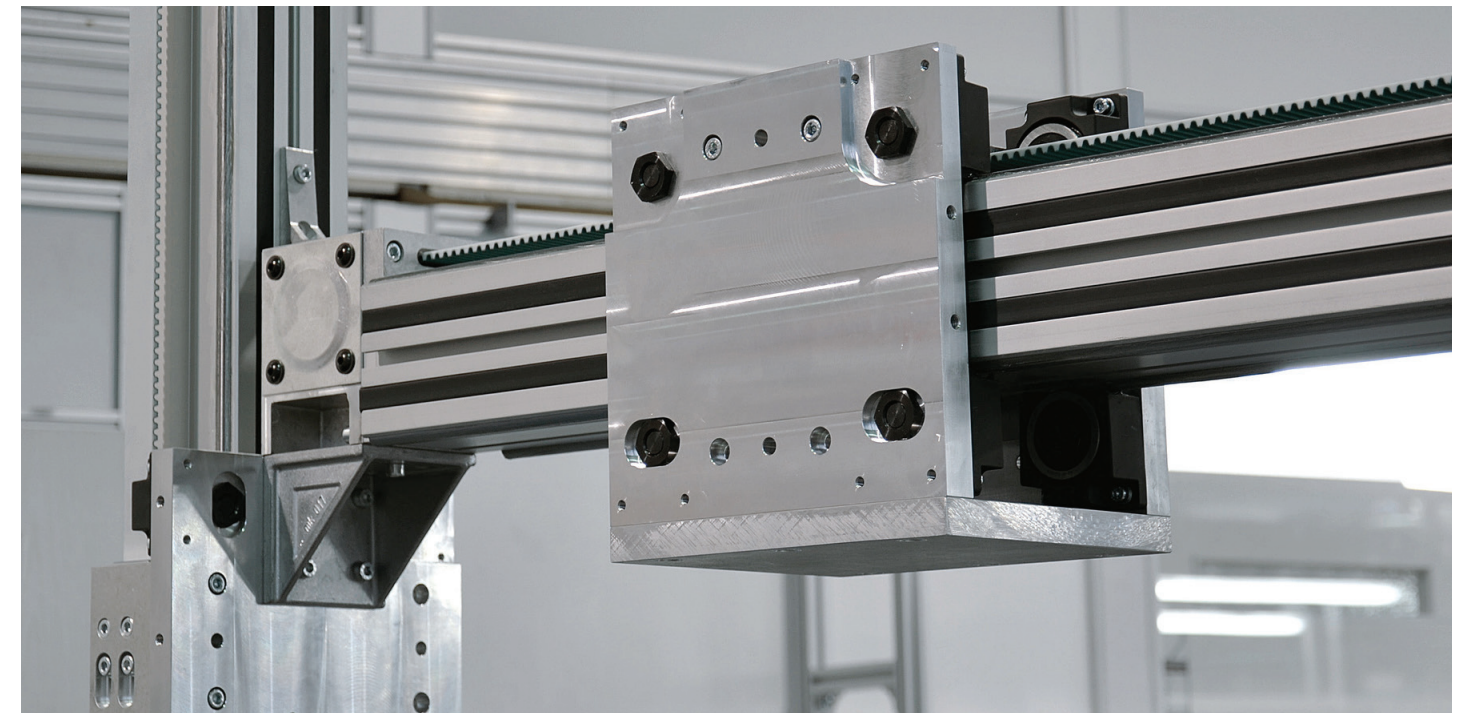

A custom LZR 2005 configuration with a vertical unit, as well as a horizontal unit. Both models feature custom carriages.



An example of a gantry using an LZR 2005 with a side-carriage and VST 2011 as the Z-axis.



As seen in this example, LZRs are typically used with conveyors to create vertical transfer units, also known as elevators.



In this example a dual-axis linear module comprised of an LZR 2011 with a side-mounted carriage plate.

Our Other Products

Extruded Aluminum Framing

mk Aluminum Framing Systems feature over 200 different profile shapes and more than 2,700 connectors and system components, all engineered for a precise fit and maximum rigidity. Forget the hassles and inflexibility of steel – the welding, grinding, painting and waiting. mk offers you fast assembly, easy reconfiguration and unlimited flexibility.

With mk Aluminum Framing you can build just about anything you can imagine. Whether it be machine bases, safety enclosures, perimeter guards, tool racks, robot stands, carts, workstations, display units or something else, with mk's aluminum framing the possibilities are nearly limitless.



VersaMove Pallet-Handling Conveyor Systems



mk North America manufactures pallet conveyors in three different platforms. This allows for the pallet-handling system to be tailored to meet your specific needs. mk believes in offering not only a better product, but also a better solution. VersaMove pallet-handling conveyors are pre-engineered and modular. The system can be easily expanded or reconfigured as your manufacturing needs change. Our workpiece pallet conveyors can be used in a variety of layouts, or combined for even greater flexibility in planning production processes.



*View all of our products and request a quote at
www.mknorthamerica.com*

Follow us on social media to get all of our latest updates and product videos.



www.mknorthamerica.com



mk North America, Inc.
an mk Technology Group Company
105 Highland Park Drive
Bloomfield, CT 06002, USA
Phone: (860) 769-5500
Fax: (860) 769-5505
www.mknorthamerica.com
info@mknorthamerica.com